



G-2RB 系列



漩涡式气泵

三相电机 50/60 Hz

真空操作

型号从 2RB 210 到 2RB 590

功率范围：

输出功率：

总压差：

吸气量：

0,25 到 4,0 kW

到 $\Delta p=490$ mbar(P)

80 到 330 m³/h

型号从 2RB 610 到 2RB 790

功率范围：

输出功率：

总压差：

吸气量：

1,6 到 7,5 kW

到 $\Delta p=670$ mbar(P)

265 到 600 m³/h

型号从 2RB 810 to 2RB 943

功率范围：

输出功率：

总压差：

吸气量：

4.0 到 29.0 kW

到 $\Delta p=750$ mbar(P)

500 到 2450 m³/h



选型和订购参数

订购型号	电机 (IP55)				重量	噪音
	频率	输出功率	额定			
			电压	电流		
Hz	kW	V	A	kg	dB(A)	
2RB 210-7AH06	50	0.25	200-240 Δ /345-415Y	2.1 Δ /1.2Y	9	53
	60	0.29	220-275 Δ /380-480Y	2.0 Δ /1.15Y		56
2RB 210-7AH16	50	0.4	200-240 Δ /345-415Y	2.6 Δ /1.5Y	10	53
	60	0.5	220-275 Δ /380-480Y	2.6 Δ /1.5Y		56
2RB 220-7HH26	50	0.7	200-240 Δ /345-415Y	3.8 Δ /2.2Y	15	55
	60	0.83	220-275 Δ /380-480Y	3.75 Δ /2.15Y		61
2RB 230-7AH06	50	0.25	200-240 Δ /345-415Y	2.1 Δ /1.2Y	10	54
	60	0.29	220-275 Δ /380-480Y	1.7 Δ /1.0Y		57
2RB 230-7AH16	50	0.4	200-240 Δ /345-415Y	2.6 Δ /1.5Y	11	54
	60	0.5	220-275 Δ /380-480Y	2.6 Δ /1.5Y		57
2RB 230-7AH26	50	0.7	200-240 Δ /345-415Y	3.8 Δ /2.2Y	12	54
	60	0.83	220-275 Δ /380-480Y	3.8 Δ /2.2Y		57
2RB 310-7AH06	50	0.55	200-240 Δ /345-415Y	2.8 Δ /1.6Y	11	55
	60	0.63	220-275 Δ /380-480Y	3.0 Δ /1.7Y		57
2RB 310-7AH16	50	0.75	200-240 Δ /345-415Y	3.8 Δ /2.2Y	12	55
	60	0.83	220-275 Δ /380-480Y	3.8 Δ /2.2Y		57
2RB 320-7HH26	50	0.85	200-240 Δ /345-415Y	4.2 Δ /2.4Y	17	58
	60	0.95	220-275 Δ /380-480Y	4.0 Δ /2.3Y		60
2RB 320-7HH36	50	1.3	200-240 Δ /345-415Y	5.7 Δ /3.3Y	18	58
	60	1.5	220-275 Δ /380-480Y	6.0 Δ /3.5Y		60
2RB 330-7AH06	50	0.55	200-240 Δ /345-415Y	2.8 Δ /1.6Y	12	56
	60	0.63	220-275 Δ /380-480Y	3.0 Δ /1.7Y		58
2RB 330-7AH16	50	0.75	200-240 Δ /345-415Y	3.8 Δ /2.2Y	13	56
	60	0.83	220-275 Δ /380-480Y	3.8 Δ /2.2Y		58
2RB 410-7AH06	50	0.7	200-240 Δ /345-415Y	3.8 Δ /2.2Y	13	63
	60	0.83	220-275 Δ /380-480Y	3.75 Δ /2.15Y		64
2RB 410-7AH16	50	0.85	200-240 Δ /345-415Y	4.0 Δ /2.3Y	16	63
	60	0.95	220-275 Δ /380-480Y	3.85 Δ /2.25Y		64
2RB 410-7AH26	50	1.3	200-240 Δ /345-415Y	5.7 Δ /3.3Y	17	63
	60	1.5	220-275 Δ /380-480Y	6.0 Δ /3.5Y		64
2RB 420-7HH36	50	1.6	200-240 Δ /345-415Y	7.5 Δ /4.3Y	25	66
	60	2.05	220-275 Δ /380-480Y	7.6 Δ /4.4Y		69
2RB 420-7HH46	50	2.2	200-240 Δ /345-415Y	9.7 Δ /5.6Y	27	66
	60	2.55	220-275 Δ /380-480Y	10.0 Δ /5.8Y		69
2RB 430-7AH06	50	0.7	200-240 Δ /345-415Y	3.8 Δ /2.2Y	14	64
	60	0.83	220-275 Δ /380-480Y	3.8 Δ /2.2Y		65
2RB 430-7AH16	50	0.85	200-240 Δ /345-415Y	4.2 Δ /2.3Y	17	64
	60	0.95	220-275 Δ /380-480Y	4.0 Δ /2.3Y		65
2RB 430-7AH26	50	1.3	200-240 Δ /345-415Y	6.6 Δ /3.8Y	18	64
	60	1.5	220-275 Δ /380-480Y	6.9 Δ /4.0Y		65

2RB 490-7AH16	50	0.6	200-240 △ /345-415Y	2.8 △ /1.6Y	14	63
	60	0.85	220-275 △ /380-480Y	3.6 △ /2.1Y		64
2RB 510-7AH06	50	0.85	200-240 △ /345-415Y	4.0 △ /2.3Y	20	64
	60	0.95	220-275 △ /380-480Y	4.2 △ /2.4Y		70
2RB 510-7AH16	50	1.3	200-240 △ /345-415Y	6.6 △ /3.8Y	22	64
	60	1.5	220-275 △ /380-480Y	6.9 △ /4.0Y		70
2RB 510-7AH26	50	1.6	200-240 △ /345-415Y	7.5 △ /4.4Y	23	64
	60	2.05	220-275 △ /380-480Y	7.6 △ /1.0Y		70
2RB 510-7AH36	50	2.2	200-240 △ /345-415Y	9.7 △ /5.6Y	25	64
	60	2.55	220-275 △ /380-480Y	10.3 △ /6.0Y		70
2RB 520-7HH46	50	3.0	200-240 △ /345-415Y	12.5 △ /7.2Y	40	72
	60	3.45	220-275 △ /380-480Y	2.6 △ /7.3Y		74
2RB 520-7HH57	50	4.0	200-240 △ /345-415Y	10.0 △ /5.8Y	44	72
	60	4.6	220-275 △ /380-480Y	9.9 △ /5.71Y		74
2RB 530-7AH06	50	0.85	200-240 △ /345-415Y	4.0 △ /2.3Y	21	65
	60	0.95	220-275 △ /380-480Y	4.2 △ /2.4Y		71
2RB 530-7AH16	50	1.3	200-240 △ /345-415Y	6.6 △ /3.8Y	23	65
	60	1.5	220-275 △ /380-480Y	6.9 △ /4.0Y		71
2RB 530-7AH26	50	1.6	200-240 △ /345-415Y	7.5 △ /4.3Y	24	65
	60	2.05	220-275 △ /380-480Y	7.6 △ /4.4Y		71
2RB 530-7AH36	50	2.2	200-240 △ /345-415Y	9.7 △ /5.6Y	26	65
	60	2.55	220-275 △ /380-480Y	10.3 △ /6.0Y		71
2RB 590-7AH26	50	1.1	200-240 △ /345-415Y	5.7 △ /3.3Y	23	64
	60	1.7	220-275 △ /380-480Y	6.0 △ /3.5Y		70

50 Hz 选型图表

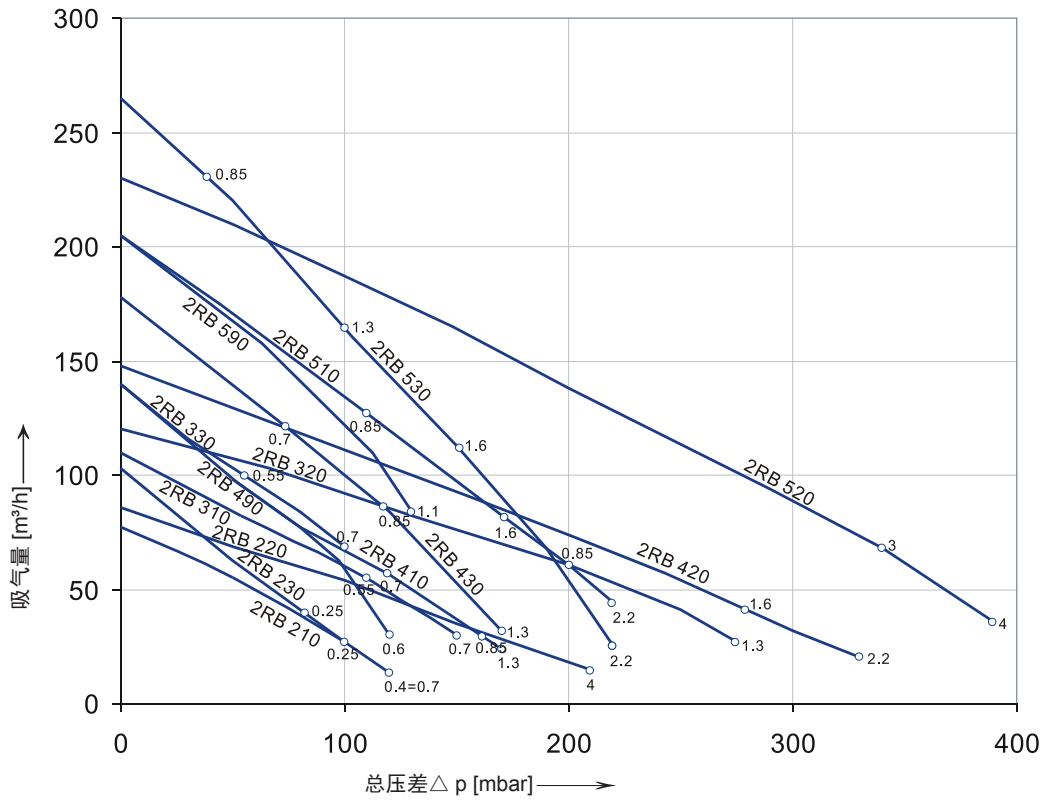

60 Hz 选型图表

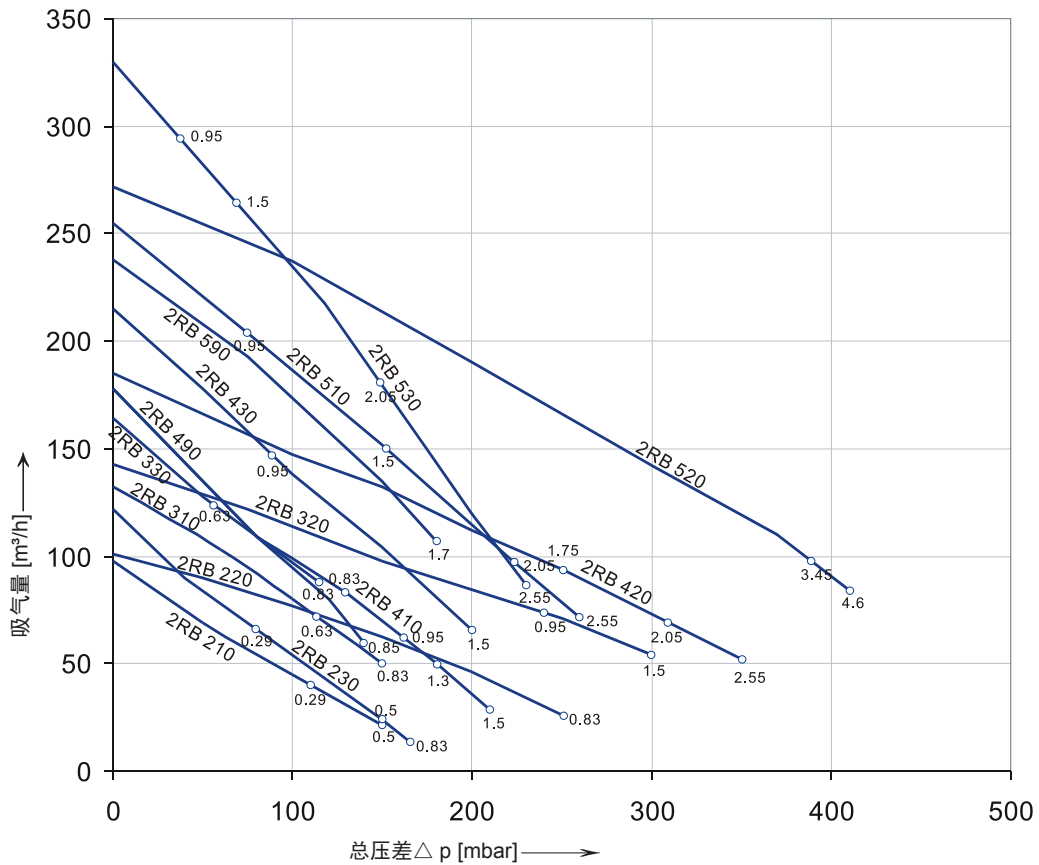

订购型号	电机 (IP55)			重量	噪音	
	频率	输出功率	额定电压			电流
	Hz	kW	V	A	kg	dB(A)
2RB 610-7AH06	50	1.6	200-240 △ /345-415Y	8.5 △ /4.9Y	25	68
	60	2.05	220-275 △ /380-480Y	8.8 △ /5.1Y		70
2RB 610-7AH16	50	2.2	200-240 △ /345-415Y	9.7 △ /5.6Y	28	69
	60	2.55	220-275 △ /380-480Y	10.3 △ /6.0Y		72
2RB 610-7AH26	50	3.0	200-240 △ /345-415Y	12.5 △ /7.2Y	34	69
	60	3.45	220-275 △ /380-480Y	12.6 △ /7.3Y		72
2RB 630-7AH06	50	1.6	200-240 △ /345-415Y	8.5 △ /4.9Y	26	70
	60	2.05	220-275 △ /380-480Y	8.8 △ /5.1Y		73
2RB 630-7AH16	50	2.2	200-240 △ /345-415Y	9.7 △ /5.6Y	29	70
	60	2.55	220-275 △ /380-480Y	10.3 △ /6.0Y		73
2RB 630-7AH26	50	3.0	200-240 △ /345-415Y	12.5 △ /7.2Y	35	70
	60	3.45	220-275 △ /380-480Y	12.6 △ /7.3Y		73
2RB 710-7AH06	50	1.6	200-240 △ /345-415Y	8.5 △ /4.9Y	27	69
	60	2.05	220-275 △ /380-480Y	8.8 △ /5.1Y		72
2RB 710-7AH16	50	2.2	200-240 △ /345-415Y	9.7 △ /5.6Y	30	69
	60	2.55	220-275 △ /380-480Y	10.3 △ /6.0Y		72
2RB 710-7AH26	50	3.0	200-240 △ /345-415Y	12.5 △ /7.2Y	36	69
	60	3.45	220-275 △ /380-480Y	12.6 △ /7.3Y		72
2RB 710-7AH36	50	4.0	345-415 △ /600-720Y	9.0 △ /5.2Y	40	63
	60	4.6	380-480 △ /660-720Y	9.0 △ /5.2Y		64
2RB 720-7HH16	50	2.2	200-240 △ /345-415Y	9.7 △ /5.6Y	43	73
	60	2.55	220-275 △ /380-480Y	10.3 △ /6.0Y		76
2RB 720-7HH26	50	3.0	200-240 △ /345-415Y	12.5 △ /7.2Y	48	73
	60	3.45	220-275 △ /380-480Y	12.6 △ /7.3Y		76
2RB 720-7HH37	50	4.3	345-415 △ /600-720Y	10.0 △ /5.2Y	54	73
	60	4.8	380-480 △ /660-720Y	10.4 △ /6.0Y		76
2RB 720-7HH47	50	5.5	345-415 △ /600-720Y	4.0 △ /2.3Y	66	73
	60	6.3	380-480 △ /660-720Y	4.2 △ /2.4Y		76
2RB 720-7HH57	50	7.5	345-415 △ /600-720Y	16.7 △ /9.6Y	73	73
	60	8.6	380-480 △ /660-720Y	17.3 △ /10.0Y		76
2RB 730-7AH06	50	1.6	200-240 △ /345-415Y	8.5 △ /4.9Y	29	70
	60	2.05	220-275 △ /380-480Y	8.8 △ /5.1Y		73
2RB 730-7AH16	50	2.2	200-240 △ /345-415Y	9.7 △ /5.6Y	32	70
	60	2.55	220-275 △ /380-480Y	10.3 △ /6.0Y		73
2RB 730-7AH26	50	3.0	200-240 △ /345-415Y	12.5 △ /7.2Y	37	70
	60	3.45	220-275 △ /380-480Y	12.6 △ /7.3Y		73
2RB 730-7AH37	50	4.0	345-415 △ /600-720Y	9.0 △ /5.2Y	43	70
	60	4.6	380-480 △ /660-720Y	9.0 △ /5.2Y		73
2RB 740-7GH37	50	4.0	345-415 △ /600-720Y	9.0 △ /5.2Y	54	74
	60	4.6	380-480 △ /660-720Y	9.0 △ /5.2Y		78
2RB 740-7GH47	50	5.5	345-415 △ /600-720Y	13.3 △ /7.7Y	69	74
	60	6.3	380-480 △ /660-720Y	13.3 △ /7.7Y		78
2RB 740-7GH57	50	7.5	345-415 △ /600-720Y	16.7 △ /9.6Y	75	74
	60	8.6	380-480 △ /660-720Y	17.3 △ /10.0Y		78
2RB 790-7AH26	50	2.2	200-240 △ /345-415Y	12.5 △ /7.2Y	36	69
	60	3.45	220-275 △ /380-480Y	12.6 △ /7.3Y		72

50 Hz 选型图表

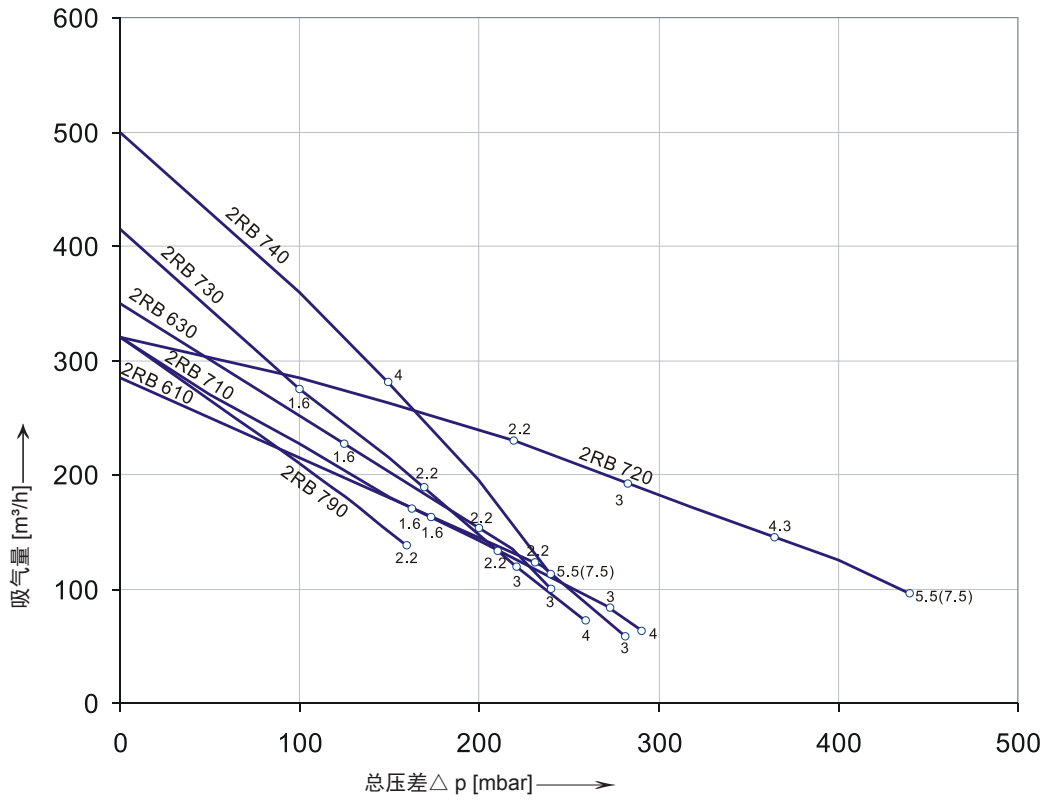

60 Hz 选型图表

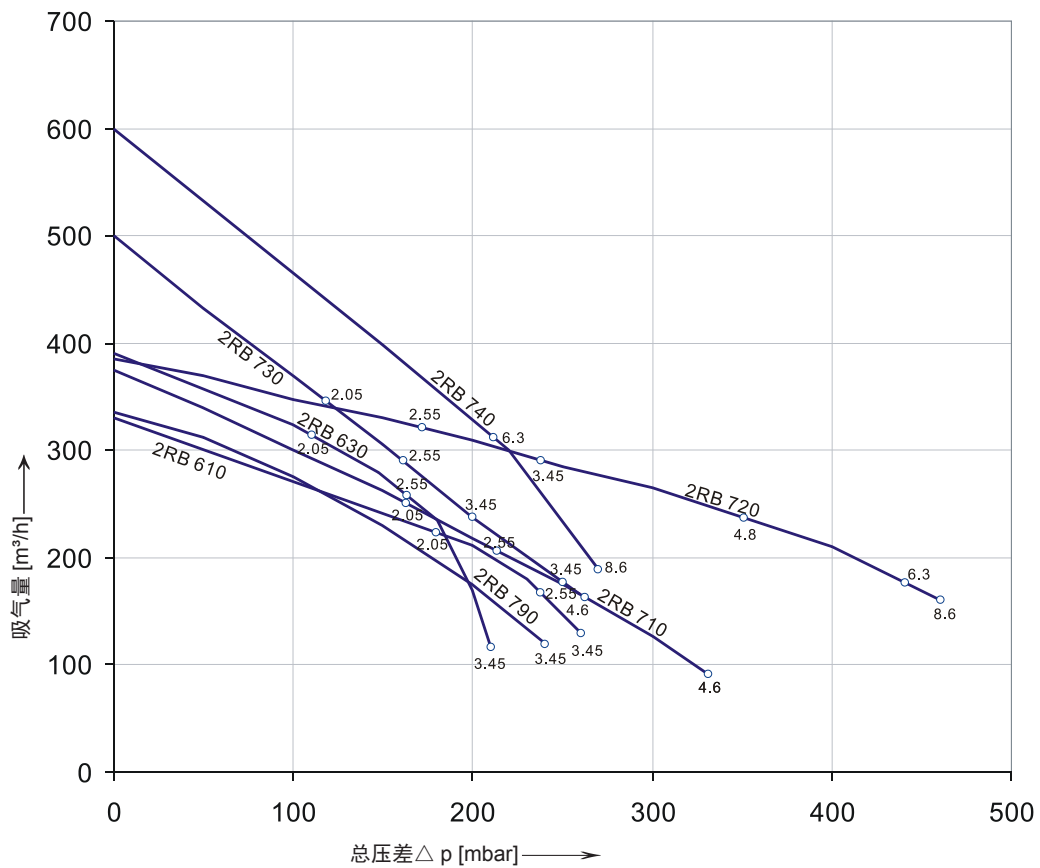

订购型号	电机 (IP55)				重量 kg	噪音 dB(A)
	频率	输出功率	额定			
			电压	电流		
Hz	kW	V	A			
2RB 810-7AH07	50	4.0	345-415 Δ /600-720Y	9.5 Δ /5.5Y	54	70
	60	4.6	380-480 Δ /660-720Y	9.5 Δ /5.5Y		74
2RB 810-7AH17	50	5.5	345-415 Δ /600-720Y	12.9 Δ /7.4Y	63	70
	60	6.3	380-480 Δ /660-720Y	12.9 Δ /7.45Y		74
2RB 810-7AH27	50	7.5	345-415 Δ /600-720Y	16.7 Δ /9.6Y	66	70
	60	8.6	380-480 Δ /660-720Y	17.3 Δ /10.0Y		74
2RB 820-7HH17	50	5.5	345-415 Δ /600-720Y	13.3 Δ /7.7Y	83	74
	60	6.3	380-480 Δ /660-720Y	13.3 Δ /7.7Y		78
2RB 820-7HH27	50	7.5	345-415 Δ /600-720Y	16.7 Δ /9.6Y	86	74
	60	8.6	380-480 Δ /660-720Y	17.3 Δ /10.0Y		78
2RB 820-7HH37	50	11.0	345-415 Δ /600-720Y	28.0 Δ /16.2Y	104	74
	60	12.6	380-480 Δ /660-720Y	10.3 Δ /6.0Y		78
2RB 820-7HH47	50	15.0	345-415 Δ /600-720Y	32.5 Δ /18.8Y	120	74
	60	17.3	380-480 Δ /660-720Y	34.5 Δ /19.9Y		78
2RB 830-7AH07	50	4.0	345-415 Δ /600-720Y	9.5 Δ /5.5Y	57	70
	60	4.6	380-480 Δ /660-720Y	9.5 Δ /5.5Y		74
2RB 830-7AH17	50	5.5	345-415 Δ /600-720Y	12.9 Δ /7.4Y	66	70
	60	6.3	380-480 Δ /660-720Y	12.9 Δ /7.45Y		74
2RB 830-7AH27	50	7.5	345-415 Δ /600-720Y	16.7 Δ /9.6Y	69	70
	60	8.6	380-480 Δ /660-720Y	17.3 Δ /10.0Y		74
2RB 840-7HH27	50	7.5	345-415 Δ /600-720Y	16.7 Δ /9.6Y	91	74
	60	8.6	380-480 Δ /660-720Y	17.3 Δ /10.0Y		78
2RB 840-7HH37	50	11.0	345-415 Δ /600-720Y	28.0 Δ /16.2Y	110	74
	60	12.6	380-480 Δ /660-720Y	29.0 Δ /16.7Y		78
2RB 910-7AH07	50	8.5	345-415 Δ /600-720Y	18.2 Δ /10.5Y	93	74
	60	9.8	380-480 Δ /660-720Y	18.2 Δ /10.5Y		79
2RB 910-7AH17	50	12.5	345-415 Δ /600-720Y	28.0 Δ /16.2Y	116	74
	60	14.5	380-480 Δ /660-720Y	29.0 Δ /16.7Y		79
2RB 910-7AH37	50	18.5	345-415 Δ /600-720Y	37.0 Δ /21.0Y	126	74
	60	21.3	380-480 Δ /660-720Y	39.0 Δ /22.5Y		79
2RB 920-7HH17	50	12.5	345-415 Δ /600-720Y	28.0 Δ /16.2Y	187	74
	60	14.5	380-480 Δ /660-720Y	29.0 Δ /16.7Y		84
2RB 920-7HH27	50	16.5	345-415 Δ /600-720Y	35.0 Δ /20.0Y	197	74
	60	19.0	380-480 Δ /660-720Y	36.5 Δ /21.0Y		84
2RB 920-7HH37	50	20.0	345-415 Δ /600-720Y	40.0 Δ /23.0Y	204	74
	60	23.0	380-480 Δ /660-720Y	42.0 Δ /24.2Y		84
2RB 920-7HH47	50	25.0	345-415 Δ /600-720Y	52.0 Δ /30.0Y	211	74
	60	29.0	380-480 Δ /660-720Y	52.0 Δ /30.0Y		84
2RB 930-7AH07	50	8.5	345-415 Δ /600-720Y	18.2 Δ /10.5Y	98	75
	60	9.8	380-480 Δ /660-720Y	18.2 Δ /10.5Y		80
2RB 930-7AH17	50	12.5	345-415 Δ /600-720Y	28.0 Δ /16.2Y	121	75
	60	14.5	380-480 Δ /660-720Y	29.0 Δ /16.7Y		80
2RB 930-7AH37	50	18.5	345-415 Δ /600-720Y	37.0 Δ /21.0Y	131	75
	60	21.3	380-480 Δ /660-720Y	39.0 Δ /22.5Y		80
2RB 940-7BH27	50	15.0	345-415 Δ /600-720Y	35.0 Δ /20.0Y	187	75
	60	17.5	380-480 Δ /660-720Y	36.5 Δ /21.0Y		84
2RB 940-7BH37	50	20.0	200-240 Δ /345-415Y	40.0 Δ /23.0Y	212	75
	60	23.0	220-275 Δ /380-480Y	42.0 Δ /24.2Y		84
2RB 940-7BH47	50	25.0	345-415 Δ /600-720Y	52.0 Δ /30.0Y	219	75
	60	29.0	380-480 Δ /660-720Y	52.0 Δ /30.0Y		84
2RB 943-7BH27 ¹⁾	50	15.0	345-415 Δ /600-720Y	35.0 Δ /20.0Y	220	75
	60	17.5	380-480 Δ /660-720Y	36.5 Δ /21.0Y		84
2RB 943-7BH37 ¹⁾	50	20.0	345-415 Δ /600-720Y	40.0 Δ /23.0Y	230	75
	60	25.0	380-480 Δ /660-720Y	42.0 Δ /24.2Y		84
2RB 943-7BH47 ¹⁾	50	29.0	345-415 Δ /600-720Y	52.0 Δ /30.0Y	235	75
	60	6.3	380-480 Δ /660-720Y	52.0 Δ /30.0Y		84

50 Hz 选型图表

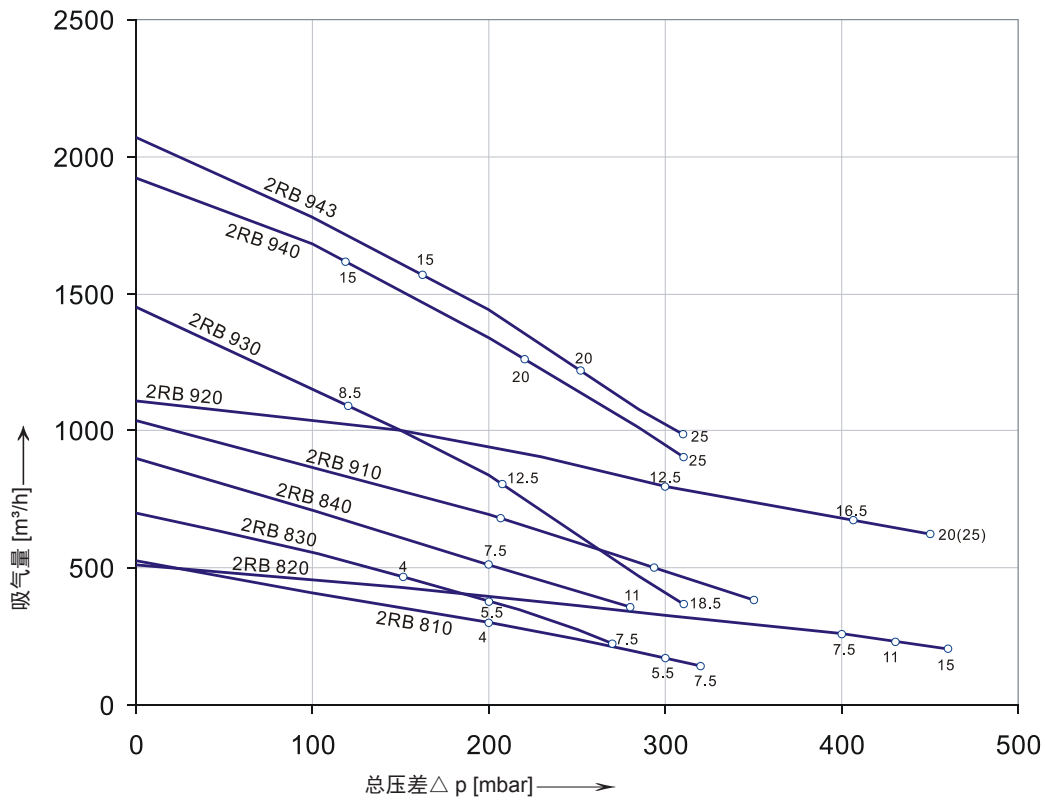

60 Hz 选型图表

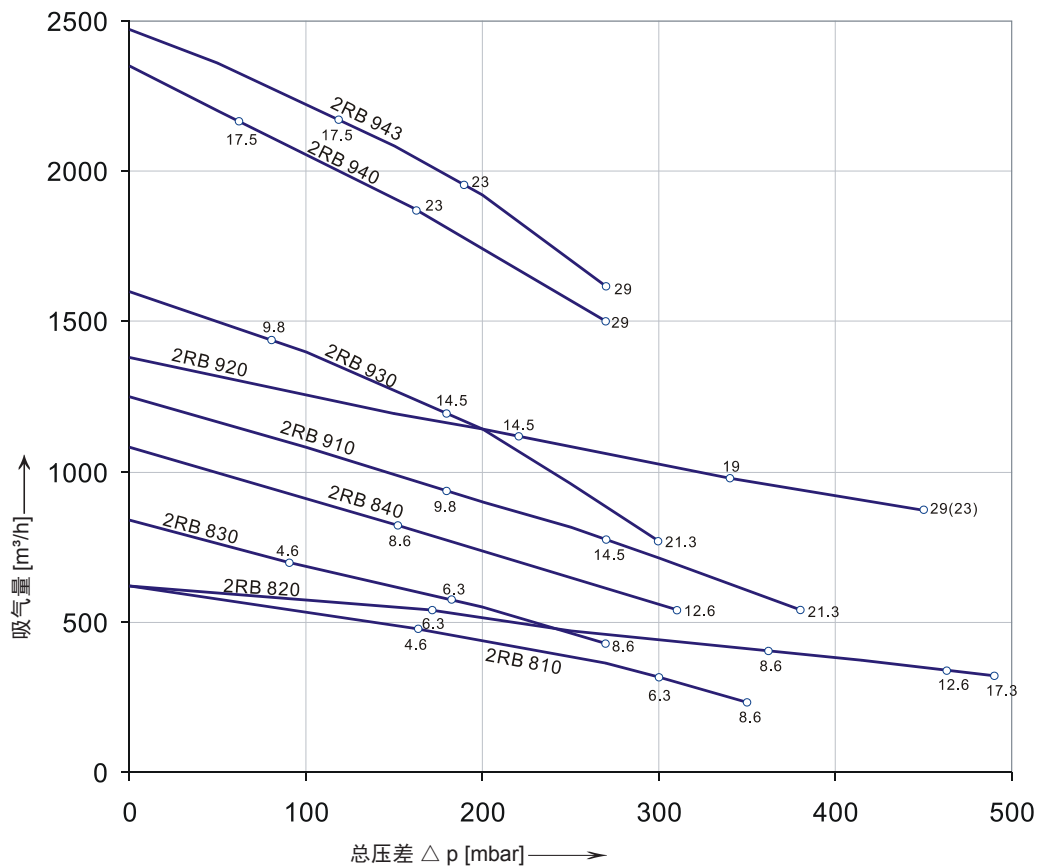

外形尺寸 [mm]

2RB210
2RB230
2RB310
2RB330

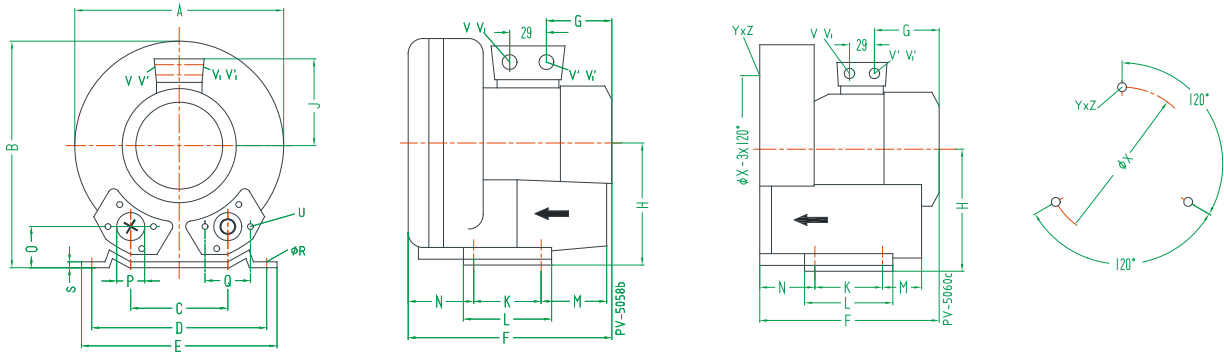

型号	相位	尺寸																	X-孔位								
		A	B	C	D	E	F	G	H	J	K	L	M	N	O	P	Q	φR	S	U	V(t-)	V'(t-)	V(t-s)	V'(t-s)	YxZ	φX	
2RB 210-7AH06	3~	246	247	90	205	230	219	92	128	101	83	108	75	71	39	G1 _{1/4}	64	10	2.5	M6x17	-	-	M25x1.5	M16x1.5	M6x15	0°/120°/240°	140
2RB 210-7AH16	3~						256	135		111											-	-	M25x1.5	M16x1.5			
2RB 230-7AH06	3~						242	102		101				82							-	-	M25x1.5	M16x1.5			
2RB 230-7AH16	3~						267	135		111											-	-					
2RB 230-7AH26	3~																				-	-					
2RB 310-7AH06	3~	268	272	93			260		141				82	69	41						-	-	M25x1.5	M16x1.5		160	
2RB 310-7AH16	3~																				-	-					
2RB 330-7AH06	3~						276							85							-	-	M25x1.5	M16x1.5			
2RB 330-7AH16	3~																				-	-					

2RB220
2RB320
2RB420

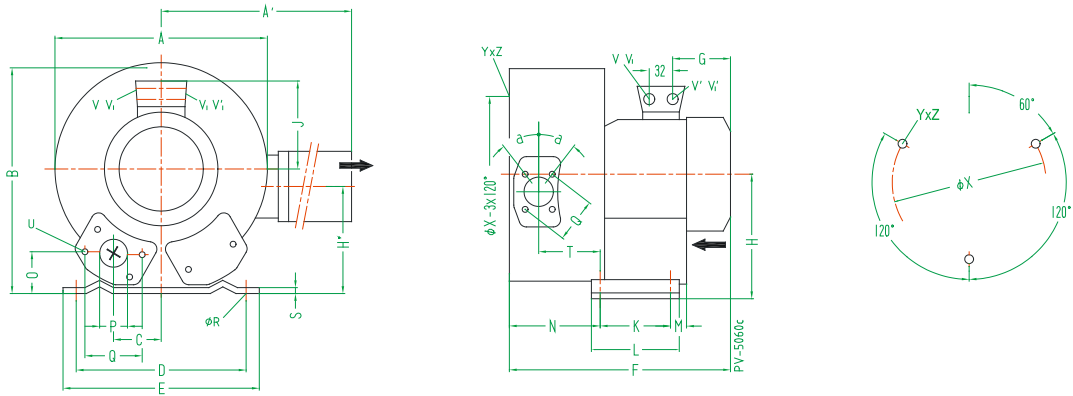

型号	相位	尺寸																	X-孔位												
		A	A'	B	C	D	E	F	G	H	H'	J	K	L	M	N	O	P	Q	φR	S	T	U	V(t-)	V'(t-)	V(t-s)	V'(t-s)	α	φX	YxZ	
2RB 220-7HH26	3~	284	316	270	45	205	230	316	135	128	106	111	83	108	75	130	39	G1 _{1/4} (51ef deep)	64	10	2.5	88	M6x17	-	-	M25x1.5	M16x1.5	27°	140	M6x15	51°/171°/291°
2RB 320-7HH36	3~	293	324	286	47			354	160	141	114	120			82	138	41					92		-	-			160			
2RB 420-7HH36	3~	322	324	315	58	225	255	401	191	154	153	128	95	130	73	151	4/5	G1 _{1/2} (51ef deep)	72	12	3	104	M6x19	-	-	M25x1.5	M16x1.5	28°	174		
2RB 420-7HH46	3~																							-	-						

2RB410
2RB430
2RB490

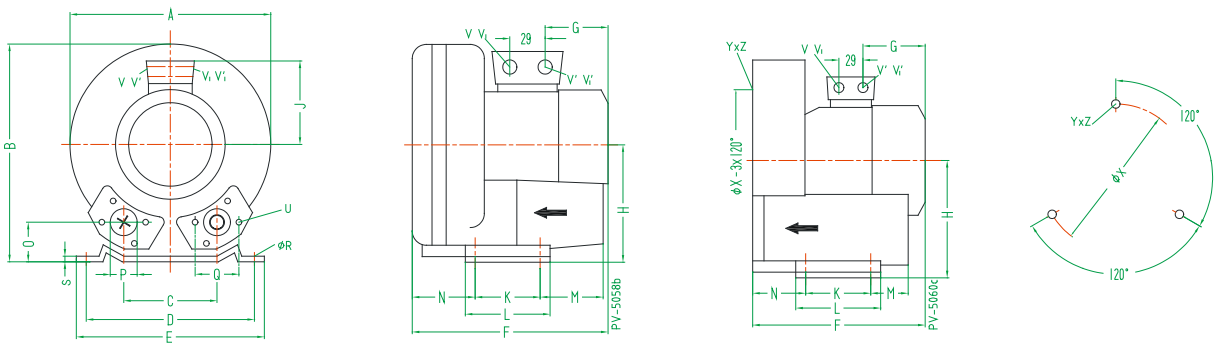

型号	相位	尺寸																	X-孔位								
		A	B	C	D	E	F	G	H	J	K	L	M	N	O	P	Q	ØR	S	U	V(t+)	V'(t+)	V''(t+)	V'''(t+)	YxZ	ØX	
2RB 410-7AH06	3~	286	302	115	225	255	269	135	154	111	95	130	70	75	46	G1/2	72	12	3	M6x19	-	-	M25x1.5	M16x1.5			174
2RB 410-7AH16	3~						292	160													-	-					
2RB 410-7AH26	3~																				-	-					
2RB 430-7AH06	3~						288	135				111									-	-	M25x1.5	M16x1.5			
2RB 430-7AH16	3~						311	160				120									-	-					
2RB 430-7AH26	3~																				-	-					
2RB 490-7AH16	3~						311	160				120									-	-	M25x1.5	M16x1.5			

2RB510
2RB530
2RB590

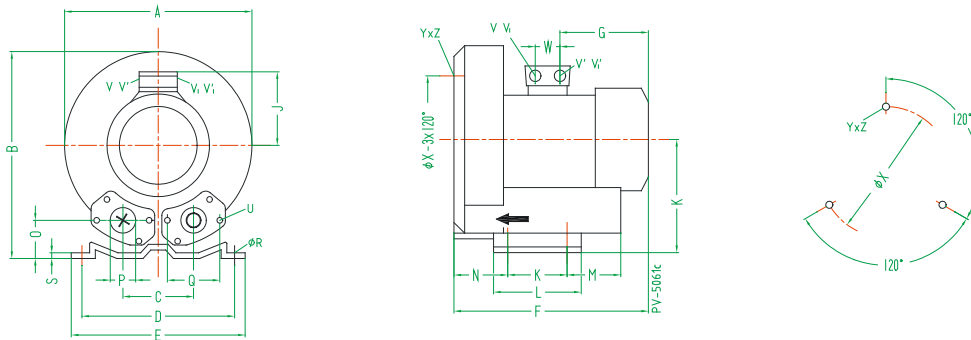

型号	相位	尺寸																	X-孔位									
		A	B	C	D	E	F	G	H	J	K	L	M	N	O	ØP	Q	ØR	S	U	V(t+)	V'(t+)	V''(t+)	V'''(t+)	YxZ	ØX	W	
2RB 510-7AH06	3~	334	337	120	260	295	314	160	175	120	115	155	96	87	48	55	83	14	4	M8x17	-	-	M25x1.5	M16x1.5	M8x20	0°/120°/240°	200	29
2RB 510-7AH16	3~																				-	-						
2RB 510-7AH26	3~						346	191				128									-	-						
2RB 510-7AH36	3~																				-	-						
2RB 530-7AH06	3~						334	160				120									-	-	M25x1.5	M16x1.5				
2RB 530-7AH16	3~																				-	-						
2RB 530-7AH26	3~						365	191				128									-	-						
2RB 530-7AH36	3~																				-	-						
2RB 590-7AH26	3~																				-	-	M25x1.5	M16x1.5				

2RB610
2RB630
2RB710
2RB730
2RB790

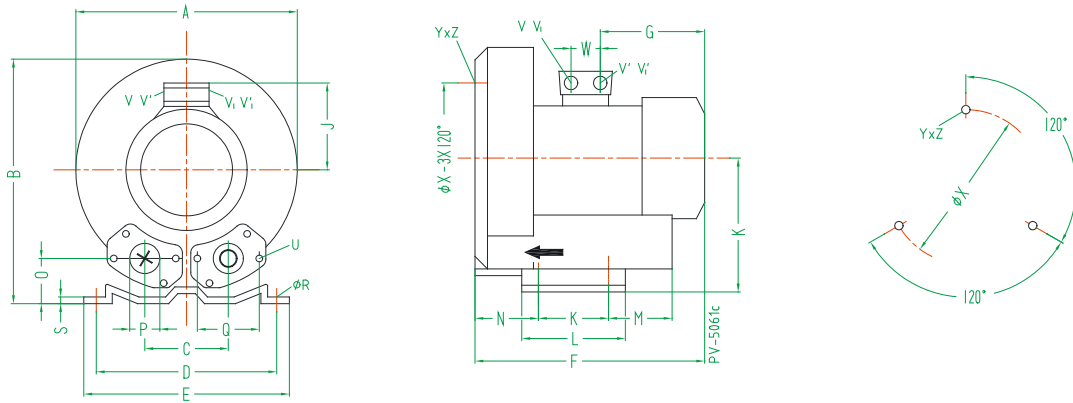

型号	相位	尺寸																	X-孔位									
		A	B	C	D	E	F	G	H	J	K	L	M	N	O	ØP	Q	ØR	S	U	V(t-)	V(t+)	V1(t-)	V1(t+)	YxZ	ØX	W	
2RB 610-7AH06	3~	360	366	122	284	325	354	191	192	128	140	180	64	74	56	56	93	13	4.5	M8x17	-	-	M25x1.5	M16x1.5	M8x20	0°/120°/240°	226	29
2RB 610-7AH16	3~																				M32x1.5	M32x1.5	M32x1.5	M32x1.5				42
2RB 610-7AH26	3~						365	188		135											M32x1.5	M32x1.5	M25x1.5	M16x1.5				29
2RB 630-7AH06	3~						372	191		128											-	-	-	-				
2RB 630-7AH16	3~																				-	-	-	-				
2RB 630-7AH26	3~						403	188		135											M32x1.5	M32x1.5	M32x1.5	M32x1.5				42
2RB 710-7AH06	3~	382	384	125	290		377	191	197	128			84	109	54	55	83	15			-	-	M25x1.5	M16x1.5	M10x20		240	29
2RB 710-7AH16	3~																				-	-	-	-				
2RB 710-7AH26	3~						409	188		135											M32x1.5	M32x1.5	M32x1.5	M32x1.5				42
2RB 710-7AH37	3~						432	209		148											-	-	-	-				
2RB 730-7AH06	3~						387	191		128											M25x1.5	M16x1.5	-	-				29
2RB 730-7AH16	3~																				-	-	-	-				
2RB 730-7AH26	3~						419	189		135											M32x1.5	M32x1.5	M32x1.5	M32x1.5				42
2RB 730-7AH37	3~						432	209		148											-	-	-	-				
2RB 790-7AH26	3~						377	185		128											-	-	M25x1.5	M16x1.5				29

2RB520-...4.
...5.
2RB720-...1.
...2.
...3.

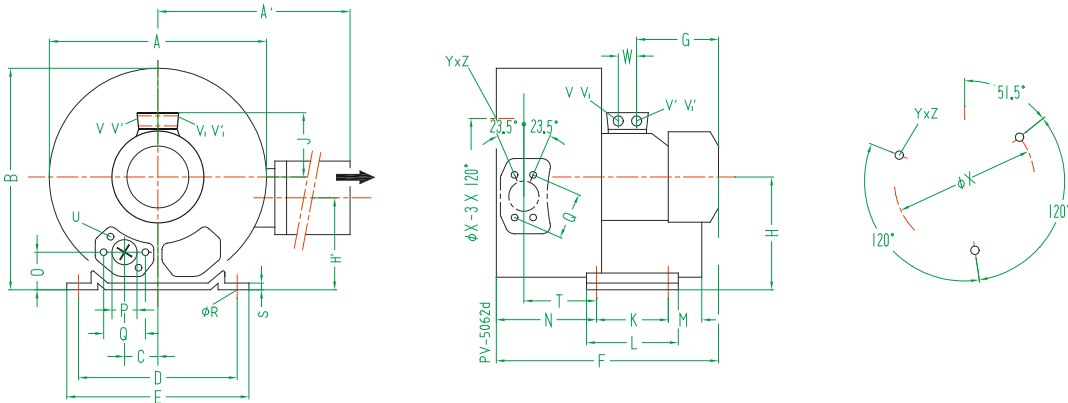

2RB720-...4
...5

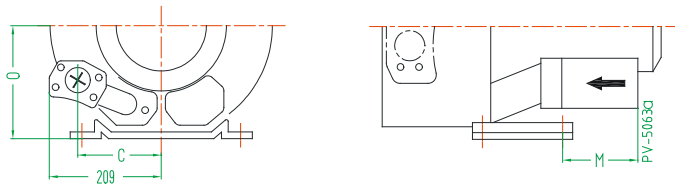

型号	相位	尺寸																				X-孔位										
		A	A'	B	C	D	E	F	G	H	H'	J	K	L	M	N	O	ØP	Q	ØR	S	T	U	V	V'	V1	V1'	ØX	YxZ	W		
2RB 520-7HH46	3~	372	411	371	60	260	295	465	190	175	144	135	115	155	98	171	48	55	83	14	4	116	M8x17	M32x1.5	M32x1.5	M32x1.5	M32x1.5	200	M8x20	51.5°/117.5°/291.5°	42	
2RB 520-7HH57	3~							499	224																							
2RB 720-7HH16	3~	426	426	410	63	290	325	473	191	162	128	140	180	84	205	53				15	4.5	130		M25x1.5	M16x1.5	-	-	240	M10x20		29	
2RB 720-7HH26	3~							496	188		135													M32x1.5	M32x1.5	M32x1.5	M32x1.5				42	
2RB 720-7HH37	3~							526	209		148																					
2RB 720-7HH47	3~				154	290		571	226		167					200																
2RB 720-7HH57	3~																															

2RB740-...3.

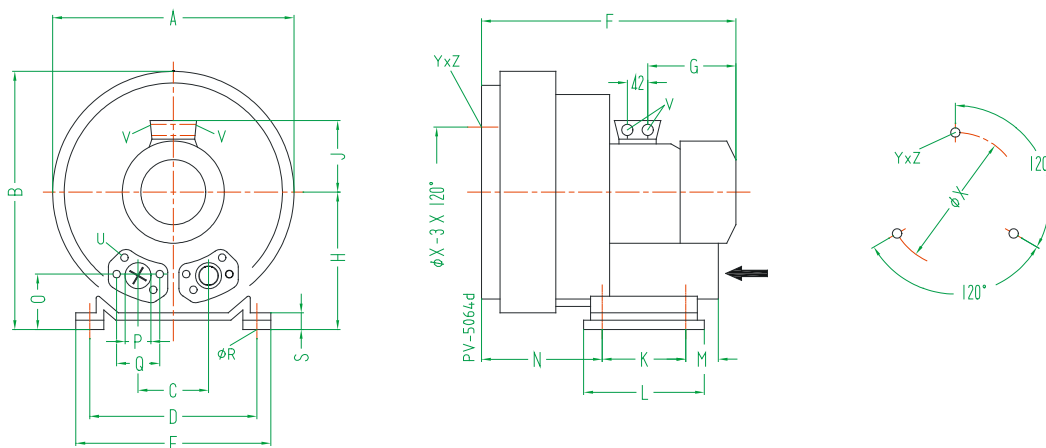

2RB740-...4
...5

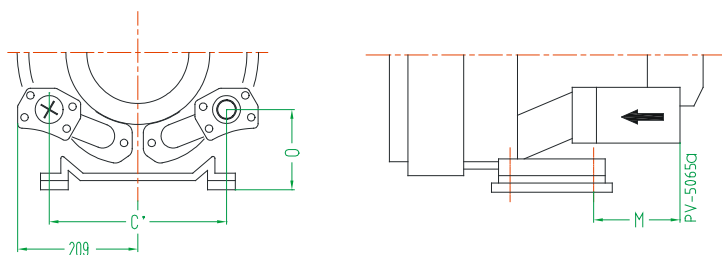

型号	相位	尺寸																			X-孔位				
		A	B	C	C'	D	E	F	G	H	J	K	L	M	N	O	ØP	Q	ØR	S		U	V	ØX	YxZ
2RB 740-7GH37	3~	420	410	125	-	290	325	526	209	197	148	140	180	84	205	153	55	83	15	64.5	M8x17	4xM32x1.5	240	M10x20	0°/120°/240°
2RB 740-7GH47	3~			-	308			571		226	257	167		200											
2RB 740-7GH57	3~			-																					

2RB810./2RB830

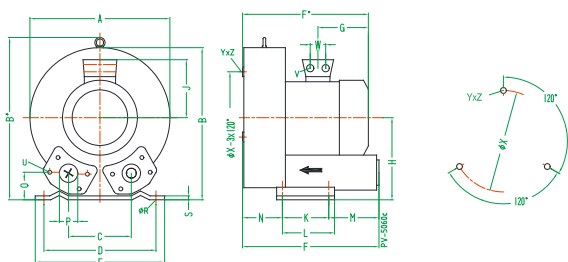

2RB820-...1.
...2.

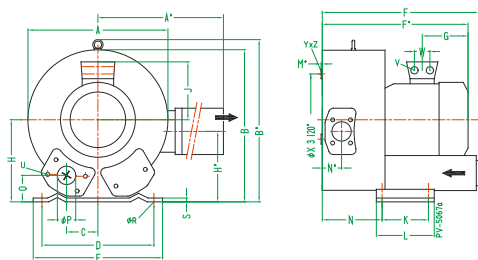

2RB820-...3.
...4.

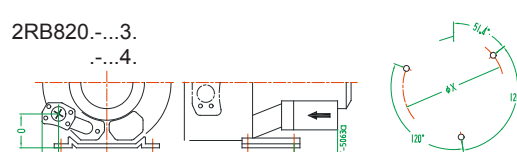

型号	相位	尺寸																				X-孔位						
		A	A'	B	B'	C	D	E	F	F'	G	H	H'	J	K	L	M	N	N'	O	ØP		ØR	S	V	W	ØX	YxZ
2RB 810-7AH07	3~	451	-	461	509	152	356	394	433	450	230	240	-	148	170	217	140	124	-	65	G2/12	15	6	4xM32x1.5	42	286	M12x20	0°/120°/240°
2RB 810-7AH17	3~									477	226			167														
2RB 810-7AH27	3~																											
2RB 820-7HH17	3~	500	549	490	509	76		545	589					199														51.4°/120°/240°
2RB 820-7HH27	3~																											
2RB 820-7HH37	3~									694	318			197										4xM40x1.5	54			
2RB 820-7HH47	3~																											
2RB 830-7AH07	3~	451	-	461	509	152		449	466	230			148			139	164		65					4xM32x1.5	42			0°/120°/240°
2RB 830-7AH17	3~								492	247			167															
2RB 830-7AH27	3~																											

2RB840-...2.

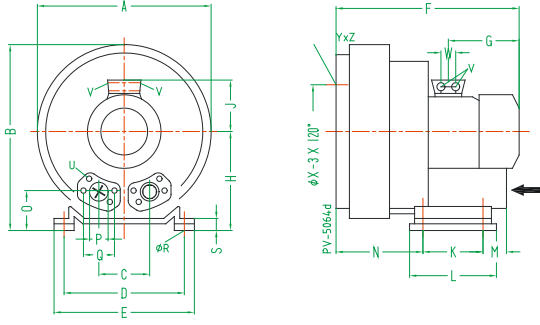

2RB840-...3.

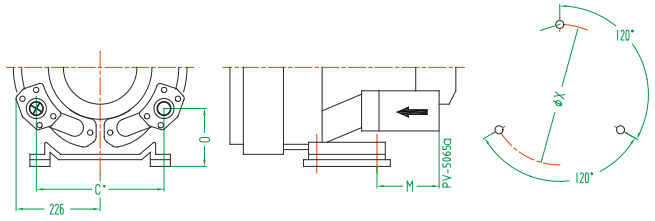

型号	相位	尺寸																			X-孔位			
		A	B	C	C'	D	E	F	G	H	J	K	L	M	N	O	φP	φR	S	V		W	φX	YxZ
2RB 840-7GH27	3~	500	550	152	-	356	394	589	247	300	167	170	217	-	236	125	G2/2	15	66	4xM32x1.5	42	286	M12x20	0°/120°/240°
2RB 840-7GH37	3~							694	318			197			312	212	165			4xM40x1.5	54			

2RB910./930

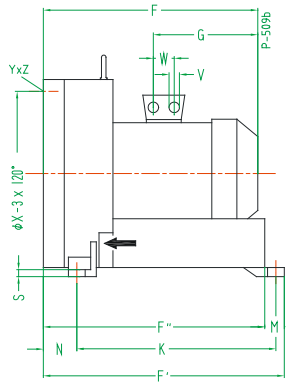
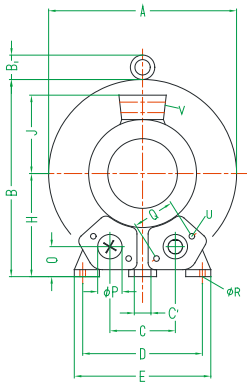

型号	相位	尺寸																					X-孔位					
		A	B	B1	C	C'	D	E	F	F'	F''	G	H	J	K	M	N	O	φP	Q	φR	S		U	V	W	φX	YxZ
2RB 910-7AH07	3~	550	569	55	207	15	360	415	525	644	605	268	300	167	533	39	89	92	100	150	15	21	M12x30	4xM32x1.5	42	490	M12x30	0°/120°/240°
2RB 910-7AH17	3~								611			345		197										4xM40x1.5	54			
2RB 910-7AH37	3~																											
2RB 930-7AH07	3~								563	682	643	268		167			127							4xM32x1.5	42			
2RB 930-7AH17	3~								649			345		197										4xM40x1.5	54			
2RB 930-7AH37	3~																											

2RB920.

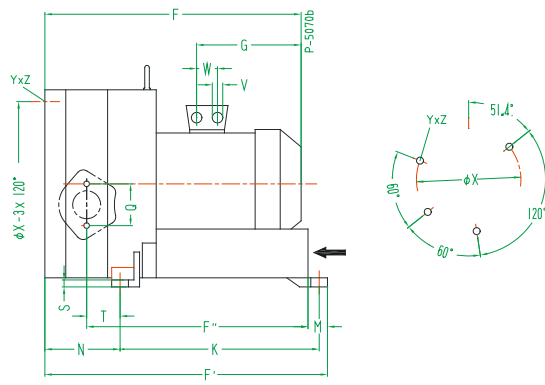
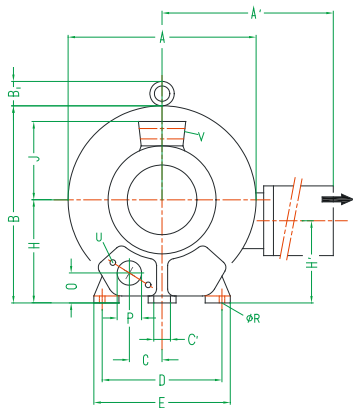

型号	相位	尺寸																					X-孔位								
		A	A'	B	B1	C	C'	D	E	F	F'	F''	G	H	H'	J	K	M	N	O	φP	Q		φR	S	T	U	V	W	φX	YxZ
2RB 920-7HH17	3~	615	780	607	16	103.5	15	360	415	752	786	634	345	300	234	197	533	39	230	92	100	150	15	21	117	M12x30	4xM40x1.5	54	490	M12x30	51.4°/120°/240°
2RB 920-7HH27	3~																														
2RB 920-7HH37	3~																														
2RB 920-7HH47	3~									812																					

2RB940.

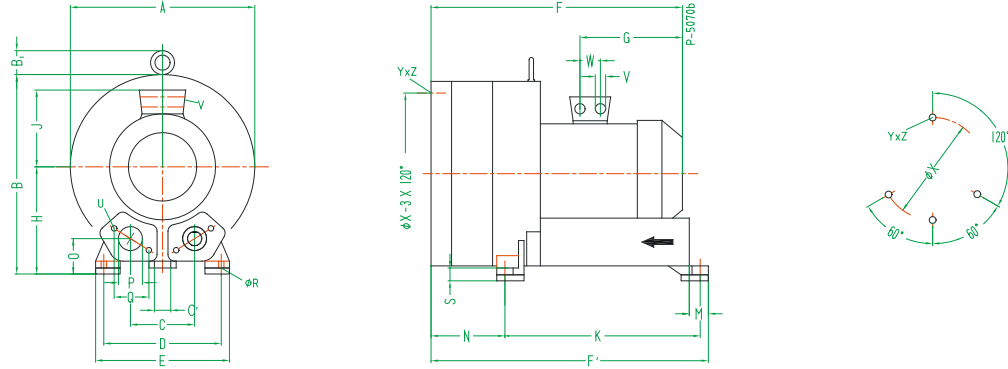

型号	相位	尺寸																			X-孔位						
		A	B	B1	C	C'	D	E	F	F'	G	H	J	K	M	N	O	φP	Q	φR		S	U	V	W	φX	YxZ
2RB 940-7BH27	3~	615	657	16	207	15	360	415	752	786	345	350	197	533	39	280	142	100	140	15	71	M12x35	4xM40x1.5	54	490	M12x30	120°/60°/60°
2RB 940-7BH37	3~																										
2RB 940-7BH47	3~							812																			

2RB943.

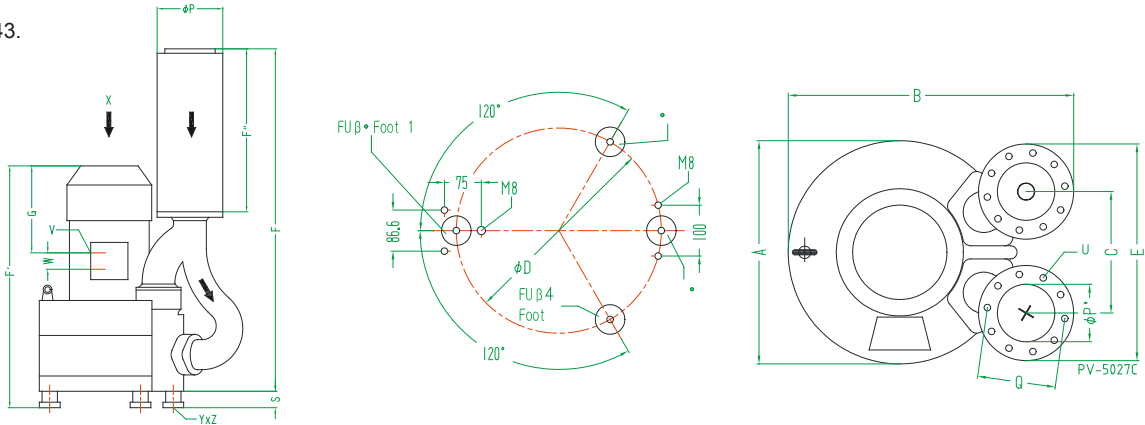

型号	相位	尺寸																YxZ
		A	B	C	D	E	F	F'	F''	G	P	P'	Q	S	U	V	W	
2RB 943-7GH27 ¹⁾	3~	615	723	307	490	526	1201	848	578	291	219	135	201	58	M8x40	4xM40x1.5	54	M12x10.5
2RB 943-7GH37 ¹⁾	3~																	
2RB 943-7GH47 ¹⁾	3~							908		351								

2RB 943:

紧用于在前改的安装

性能曲线:

性能曲线是在抽吸 15°C 空气，排气压力 1013mbar 的工况下测出的，允差 ±10%，吸入空气和环境温度不超过 25°C 时，极可达到图示总压差。

噪音:

测量 - 表面噪音 - 压力按照 DIN EN 21680 标准。测量距离是 1 米，气泵的出风口（压力）和进气口（真空）各连接一条软管，但是不安装释压阀。

声明:

关于特别引述的性能曲线，数据和重量的变化，恕不另行通知。