

下面的性能曲线是在抽吸 15°C 空气，排气压力 1013mbar 的工况下测出的，允差 ±10%，吸入空气和环境温度不超过 25°C 时，即可达到图示总压差。

The performance curves are valid for pumping air at 15°C at the inlet flanges with an air pressure of 1.013mbar and a tolerance of ±10%. The total pressure differences are valid up to an intake and ambient temperature of 25°C .

NO	Rated Speed	Rated power	Maximim Air flow	Maximim vacuum	maximim pressure	Sound-level	Weight approx	Vacuum rellet		
编号	转速	配置功率	最大流量	最大真空	最大压力	噪音	重量	Items×type		
	RPM	KW	m³/h	mbar	mbar	dB(A)	Kg	2BX		
1	3000	5.5	500	-240	260	74	31	2×...2110/...2145		
	3600	6.3	600	-210	200	78				
	4200	7.5	700	-140	120	80				
	5000	8.8	800	-50	30	84				
2	3000	7.5	500	-240	320	73				
	3600	8.6	600	-270	300	75				
	4200	10.0	700	-200	200	78				
	5000	12.0	800	-110	80	84				

Vacuum Selection diagram —真空选型图表

Compressor Celetion Diagram —压缩选型图表

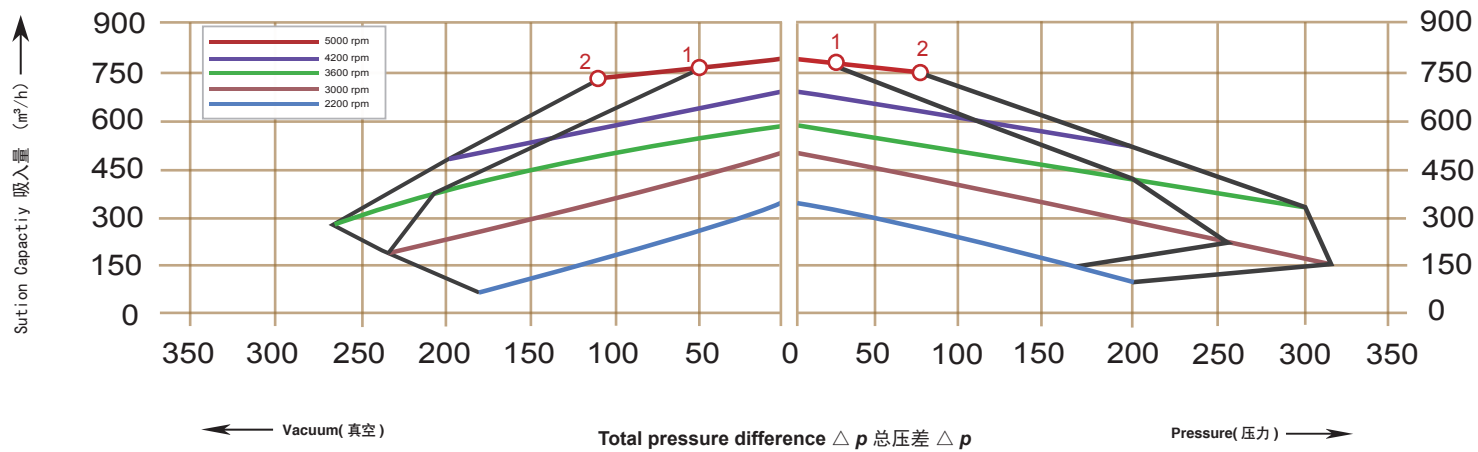

Dimensions for belt drive side channel blower 皮带式侧风道风机尺寸

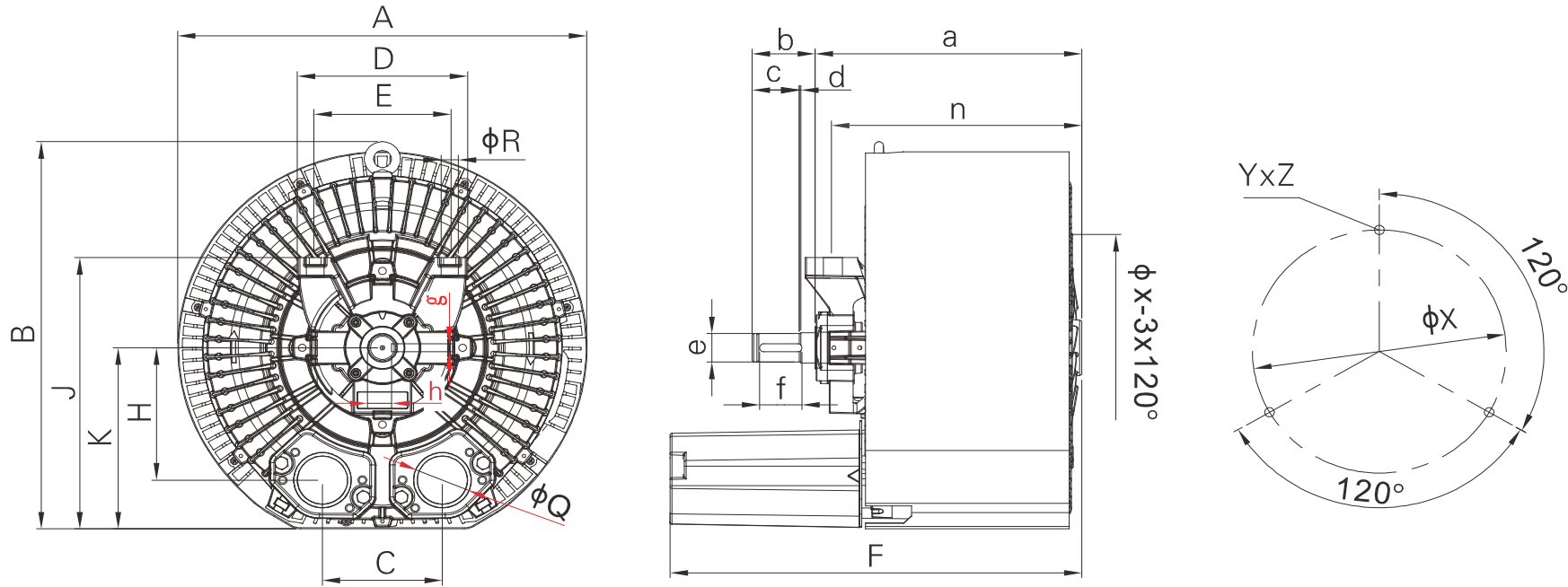

型号 Type	A	B	C	D	E	F	H	J	K	φQ	φR
2RB 743-1HY99	426	421	63	177	140	429	144	295	197	55	18
型号 Type	a	b	c	d	e	f	g	h	n	Y*Z	φX
2RB 743-1HY99	278	60	44	2	28	40	8	24	265	M10×20	240