



下面的性能曲线是在抽吸 15°C 空气，排气压力 1013mbar 的工况下测出的，允差 ±10%，吸入空气和环境温度不超过 25°C 时，即可达到图示总压差。

The performance curves are valid for pumping air at 15°C at the inlet flanges with an air pressure of 1.013mbar and a tolerance of ±10%. The total pressure differences are valid up to an intake and ambient temperature of 25°C .

NO	Rated Speed	Rated power	Maximim Air flow	Maximim vacuum	maximim pressure	Sound-level	Weight approx	Vacuum rellet
编号	转速	配置功率	最大流量	最大真空	最大压力	噪音	重量	Items × type
	RPM	KW	m³/h	mbar	mbar	dB(A)	Kg	2BX
1	3000	12.5	1370	-190	190	75	76	2×...750/...860
	3600	14.5	1600	-150	150	80		
	4200	17.5	1850	-130	120	82		
2	3000	15.0	1370	-280	260	75		
	3600	17.5	1600	-240	220	80		
	4200	21.6	1850	-210	190	82		
3	3000	18.5	1370	-310	320	75		
	3600	21.3	1600	-300	280	80		
	4200	26.0	1850	-260	250	82		

Vacuum Selection diagram — 真空选型图表

Compressor Celetion Diagram — 压缩选型图表

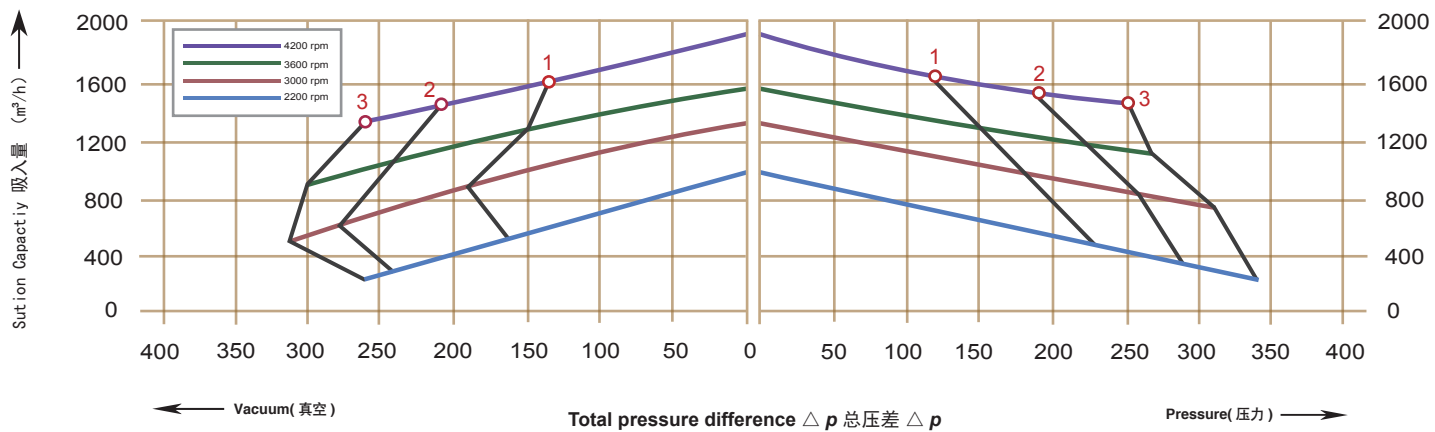

Dimensions for belt drive side channel blower

皮带式侧风道风机尺寸

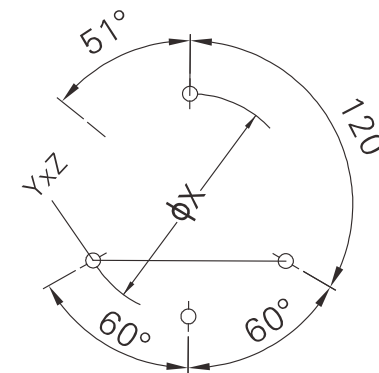
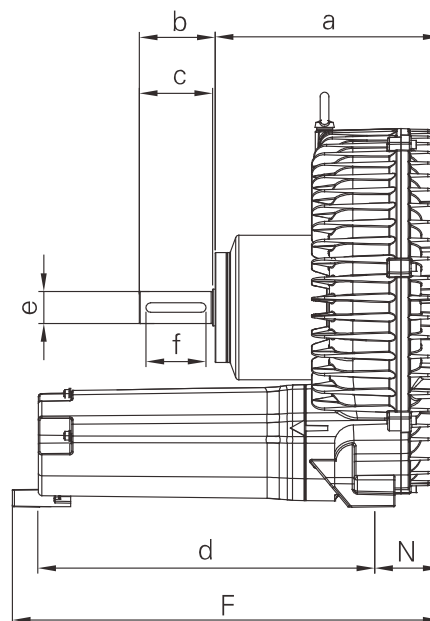
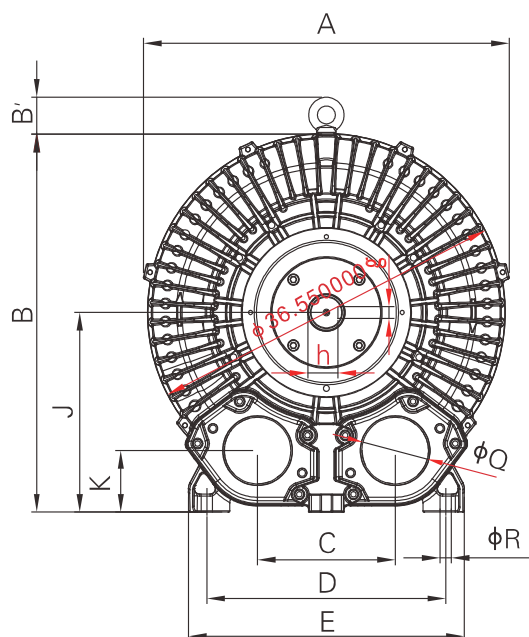

型号 Type	A	B	B'	C	D	E	F	J	K	N	φQ	φR
2RB 933-1HY99	550	569	55	207	360	415	682	300	92	127	100	15
型号 Type	a	b	c	d	e	f	h	g	Y*Z	φX		
2RB 933-1HY99	378	114	110	533	48	90	42	14	M12×30	490		